

Unit B – Practical 8

Experimental determination of internal resistance of a cell

Safety

There are no safety issues concerning this experiment.

Apparatus and materials

- 1.5 V cell
- 5 Ω resistor
- variable resistor
- switch
- ammeter and voltmeter (or two digital multimeters)
- connecting wires

Introduction

When a power source, like a cell, is not ideal it has an internal resistance. Some of the energy provided in the circuit is dissipated in the internal resistance. In this experiment you will determine the internal resistance and electromotive force (emf) of a cell.

When a cell of emf ε and internal resistance r is connected to a circuit of total resistance R then:

$$\varepsilon = IR + Ir \text{ or } IR = \varepsilon - Ir$$

where I is the current in the circuit.

But the terminal potential difference (pd) across the cell V_t is equal to IR and therefore:

$$V_t = E - Ir$$

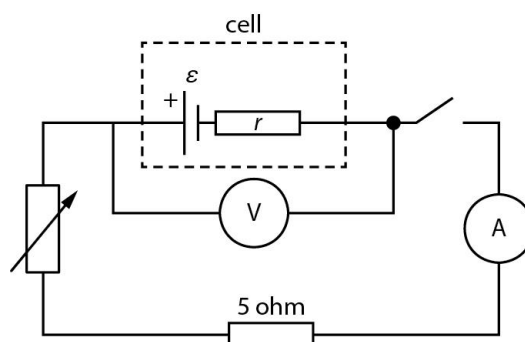

Procedure

- 1 Construct the circuit as shown in the diagram.
- 2 If you are using multimeters, set one in the V DC range (voltmeter) and one in the A DC range (ammeter).
- 3 Set the variable resistor at a middle setting, close the switch and record the measurements of V_t and I in a suitable table. Keep the switch closed for the minimum amount of time required to take the measurements.

